

OIL-INJECTED ROTARY SCREW COMPRESSORS

GA 30⁺-90/GA 37-90 VSD
(30-90 kW/40-125 hp)

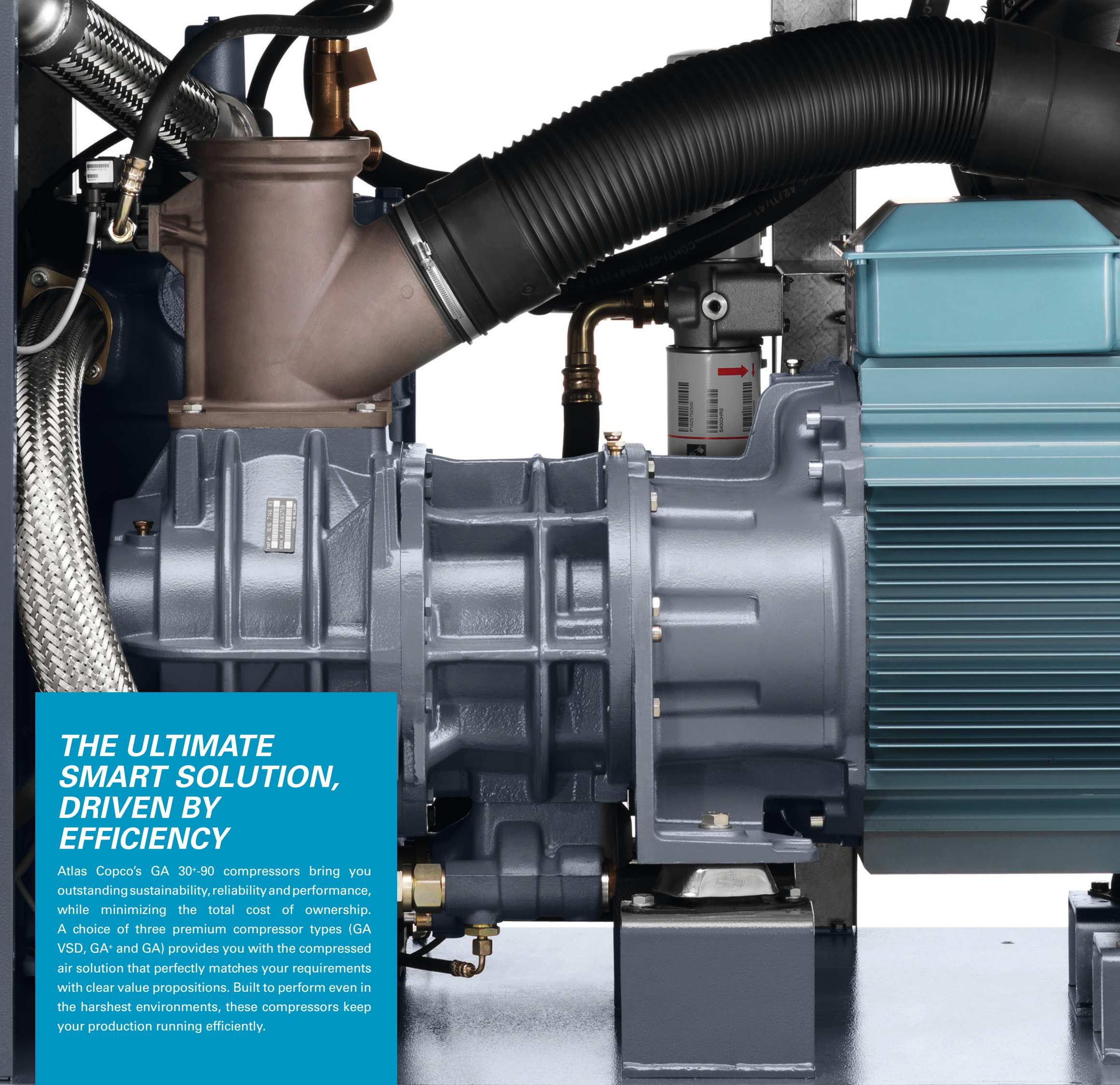



THE ULTIMATE SMART SOLUTION, DRIVEN BY EFFICIENCY

Atlas Copco's GA 30+90 compressors bring you outstanding sustainability, reliability and performance, while minimizing the total cost of ownership. A choice of three premium compressor types (GA VSD, GA+ and GA) provides you with the compressed air solution that perfectly matches your requirements with clear value propositions. Built to perform even in the harshest environments, these compressors keep your production running efficiently.

GA VSD ULTIMATE ENERGY SAVER

- Unique integrated Variable Speed Drive (VSD) technology for on average 35% energy savings.
- Industry-leading operating turndown range and flexible pressure selection: 4-13 bar.
- Start under system pressure due to special VSD motor, no idling time.
- Integrated Dryer Saver Cycle saves up to 60% of the dryer's electrical consumption.
- Smart Elektronikon® graphic compressor controller with high-definition color display working to a set point minimizes pressure drops.

GA+ INDUSTRY-LEADING PERFORMANCE

- Industry-leading Free Air Delivery and low energy consumption.
- Low noise emission suitable for workplace installation.
- Environmentally-friendly R410A integrated dryer reduces footprint and pressure drops.
- Smart Elektronikon® graphic compressor controller with high-definition color display.

GA PREMIUM COMPRESSOR

- High performance Free Air Delivery.
- Premium quality at the lowest initial investment.
- Efficient environmentally-friendly R410A integrated dryer reduces footprint and pressure drops.
- Ensured efficiency of Elektronikon® controller with connectivity.

VSD: DRIVING DOWN YOUR ENERGY COSTS

Over 80% of a compressor's lifecycle cost is taken up by the energy it consumes. Moreover, the generation of compressed air can account for more than 40% of a plant's total electricity bill. To cut your energy costs, Atlas Copco pioneered Variable Speed Drive (VSD) technology in the compressed air industry. VSD leads to major energy savings, while protecting the environment for future generations. Thanks to continual investments in this technology, Atlas Copco offers the widest range of integrated VSD compressors on the market.

Why Atlas Copco Variable Speed Drive technology?

- On average 35% energy savings during fluctuations in production demand with an extensive turndown range.
- Integrated Elektronikon Graphic controller controls the motor speed and high efficiency frequency inverter.
- No wasted idling times or blow-off losses in normal operation.
- Compressor can start/stop under full system pressure without the need to unload with special VSD motor.
- Eliminates peak current penalty during start-up.
- Minimizes system leakage due to a lower system pressure.
- EMC Compliance to directives (2004/108/EG).

NO IDLING TIME

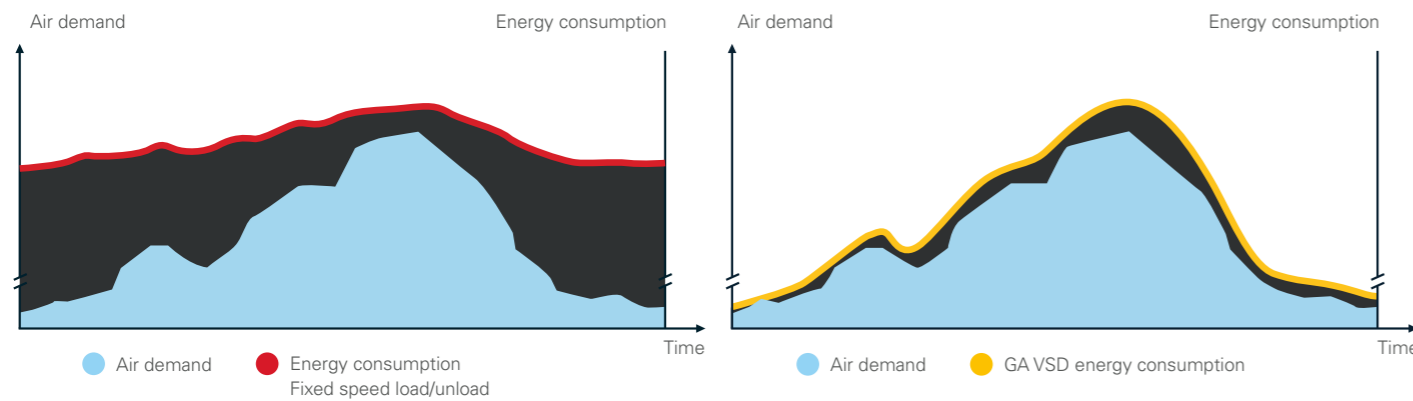

In almost every production environment, air demand fluctuates depending on different factors such as the time of the day, week or even month. Extensive measurements and studies of compressed air demand profiles show that many compressors have substantial variations in air demand. Only 8% of all installations have a more stable air demand.

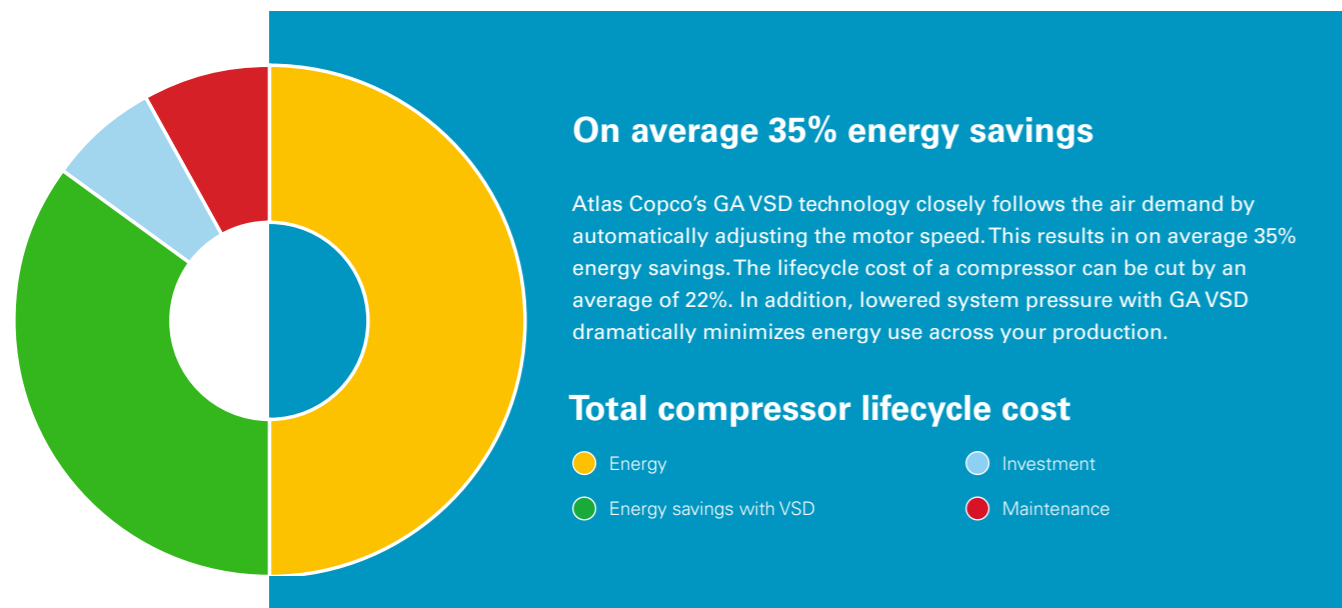

How GA VSD technology saves energy

Contact your local Atlas Copco representative for an audit of your compressed air system. A real-time measurement simulation and audit report can be provided with recommendations for additional savings and sizing to meet your compressed air needs.

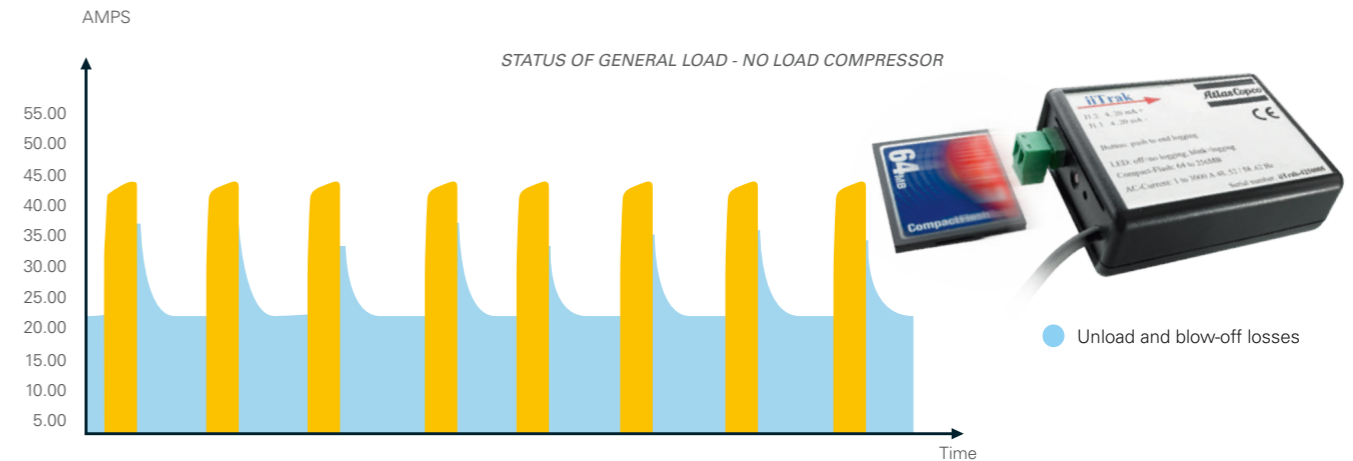

What is unique about the integrated Atlas Copco GA VSD?

Contact your local Atlas Copco representative for an audit of your compressed air system. A real-time measurement simulation and audit report can be provided with recommendations for additional savings and sizing to meet your compressed air needs.

- 1 The Elektronikon® controls both the compressor and the integrated converter, ensuring maximum machine safety within parameters.
- 2 Flexible pressure selection from 4 to 13 bar with electronic gearing reduces electricity costs.
- 3 Special electric motor specifically designed for VSD operation (inverter duty motor). Bearings are protected against induced bearing currents. Both motor and converter are perfectly tuned for highest efficiency across the entire speed range.
- 4 Electric motor specifically designed for low operating speeds with clear attention to motor cooling and compressor cooling requirements.
- 5 All Atlas Copco GA VSD compressors are EMC tested and certified. External sources do not influence compressor operation, nor does the compressor affect the operation of other instruments via emissions or via the power supply line.
- 6 Mechanical enhancements ensure that all components operate below critical vibration levels throughout the entire compressor speed range.
- 7 A highly efficient frequency converter in a cool overpressure cubicle ensures stable operation in high ambient temperatures up to 50°C/122°F*. * Standard up to 46°C/114.8°F.
- 8 No 'speed windows' that can jeopardize the energy savings and the stable net pressure. Turndown capability of the compressor is maximized to 80-85%.
- 9 The cubicle cooling booster increases the lifetime of electrical components due to a cool cubicle in overpressure and reduced dust ingress.
- 10 Net pressure band is maintained within 0.10 bar, 1.5 psi.

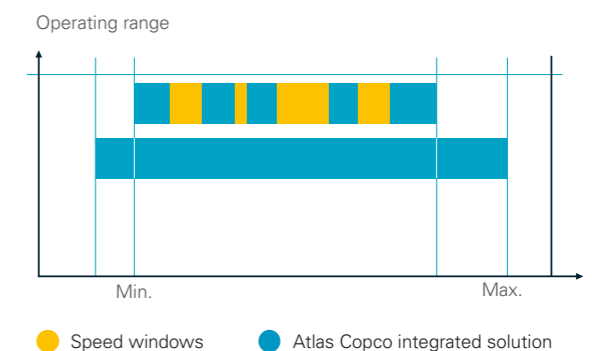
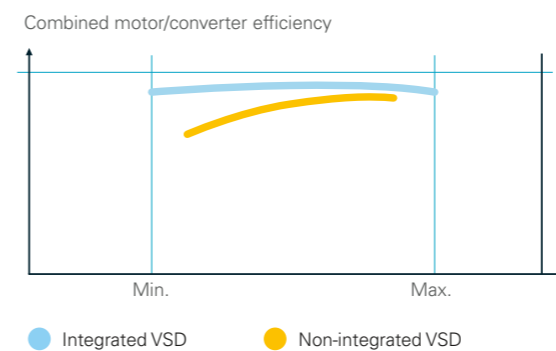

HIGH RELIABILITY AND SMART ENERGY



11 Integrated highly efficient R410A dryer

- Excellence in air quality.
- 50% reduction in energy consumption compared to traditional dryers.
- Zero ozone depletion.
- Incorporates optional UD+ filters according to Class 1.4.2.

1 Maintenance-free drive system

- 100% maintenance-free; totally enclosed and protected against dirt and dust.
- Suitable for harsh environments.
- High-efficiency drive arrangement; no coupling or slippage losses.
- Standard up to 46°C/115°F and for high ambient version 55°C/131°F.

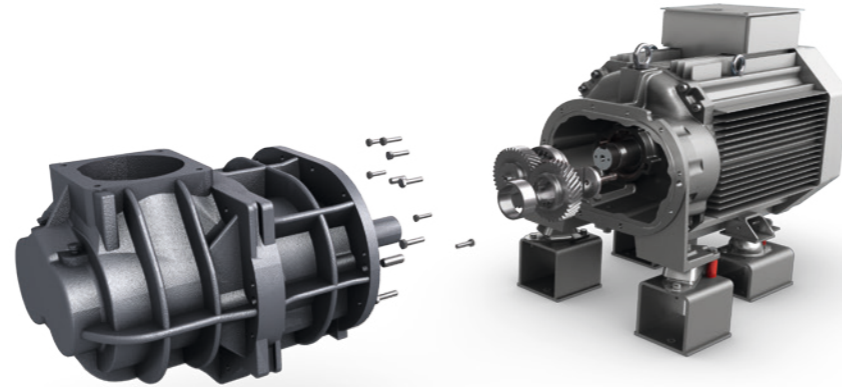

10 NEOS drive

- Atlas Copco's in-house designed inverter for GA VSD compressors.
- IP5X protection degree.
- A robust, aluminum enclosure for trouble-free operation in the harshest conditions.
- Fewer components: compact, simple and user-friendly.



2 IE3 / NEMA Premium Efficiency electrical motors

- IP55, insulation Class F, B rise.
- Non-drive side bearing greased for life.
- Designed for continuous operation in harsh environments.

3 Robust spin-on oil filter

- High-efficiency, removing 300% smaller particles than a conventional filter.
- Integrated bypass valve with the oil filter.

4 SIL Smart inlet lock system for GA VSD compressors

- Superior designed vacuum and air pressure controlled valve with minimal pressure drop and no springs.
- Smart stop/start which eliminates back-pressure oil vapor.



9 Cubicle cooling booster

- Cubicle in overpressure minimizes ingress of conductive dust.
- Electrical components remain cool, enhancing lifetime of components.

8 Elektronikon® for remote monitoring

- Integrated smart algorithms reduce system pressure and energy consumption.
- Monitoring features include warning indications, maintenance scheduling and online visualization of machine's condition.

7 Heavy-duty air intake filter

- Protects the compressor components by removing 99.9% of dirt particles down to 3 microns.
- Differential inlet pressure for proactive maintenance while minimizing pressure drop.

5 Separate oversized oil cooler and aftercooler

- Low element outlet temperatures, ensuring long oil lifetime.
- Removal of nearly 100% condensate by mechanical separator.
- No consumables.
- Eliminates possibility of thermal shocks in coolers.

6 Electronic no-loss water drain

- Ensures constant removal of condensate.
- Manual integrated bypass for effective condensate removal in case of power failure.
- Integrated with compressor's Elektronikon® with warning/alarm features.



A STEP AHEAD IN MONITORING AND CONTROLS

The next-generation Elektronikon® operating system offers a wide variety of control and monitoring features that allow you to increase your compressor's efficiency and reliability. To maximize energy efficiency, the Elektronikon® controls the main drive motor and regulates system pressure within a predefined and narrow pressure band.



Improved user-friendliness

- 3.5-inch high-definition color display with clear pictograms and extra 4th LED indicator for service.
- Graphical display of key parameters (day, week, month) and 32 language settings.
- Internet-based compressor visualization using a simple Ethernet connection.
- On-screen Delayed Second Stop function and VSD savings indication.
- Graphical indication Serviceplan, remote control and connectivity functions.
- Software upgrade available to control up to 6 compressors by installing the optional integrated compressor controller.



Online & mobile monitoring

Monitor your compressors over the Ethernet with the new Elektronikon® controller. Monitoring features include warning indications, compressor shut-down and maintenance scheduling. The Atlas Copco App is available for iPhone/Android phones as well as iPad and Android tablets. It allows fingertip monitoring of your compressed air system through your own secured network.

Optional integrated compressor controller

Install, with a simple license, the optional integrated compressor controller and get simple, central control to reduce system pressure and energy consumption in installations of up to 4 (ES4i) or 6 (ES6i) compressors.

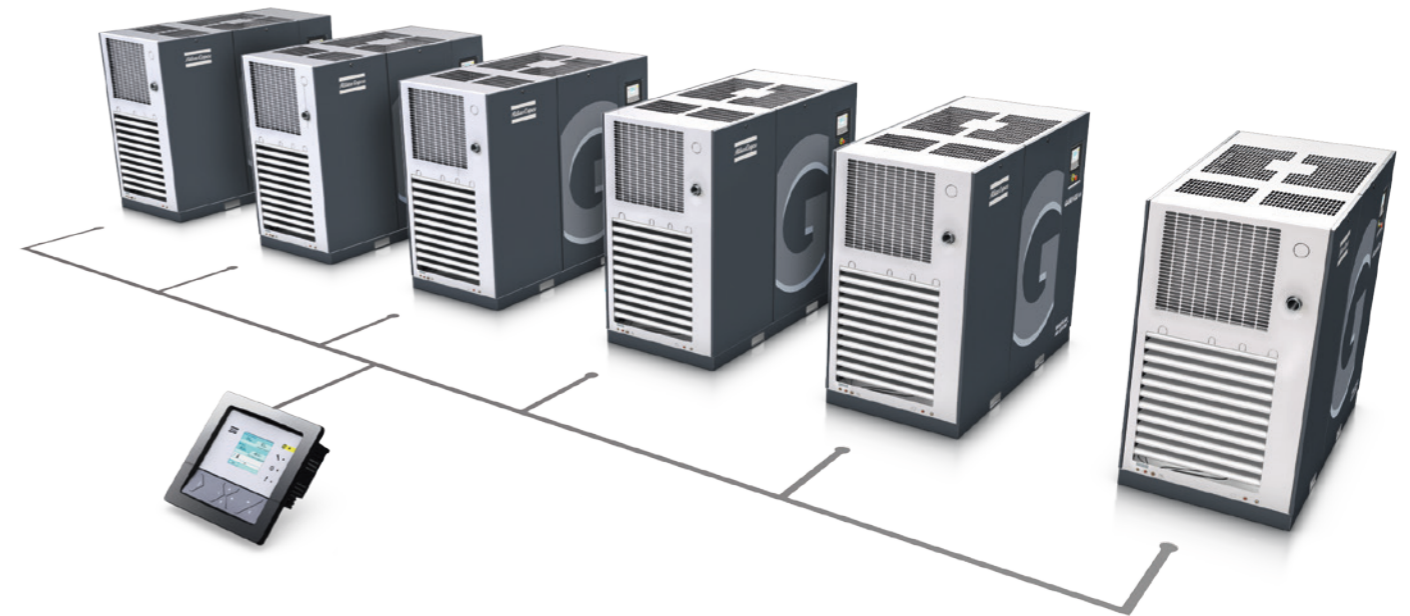

Dual pressure set point & Delayed Second stop

Most production processes create fluctuating levels of demand which, in turn, can create energy waste in low use periods. Using either the standard or graphic Elektronikon® controller, you can manually or automatically create two different system pressure bands to optimize energy use and reduce costs at low use times. In addition, the sophisticated Delayed Second Stop (DSS) runs the drive motor only when needed. As the desired system pressure is maintained while the drive motor's run time is minimized, energy consumption is kept at a minimum.

Without DSS

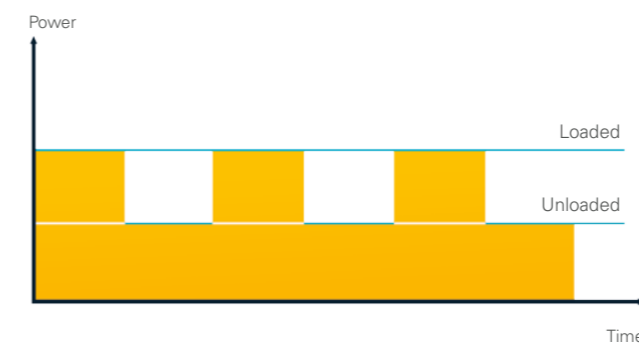

With DSS

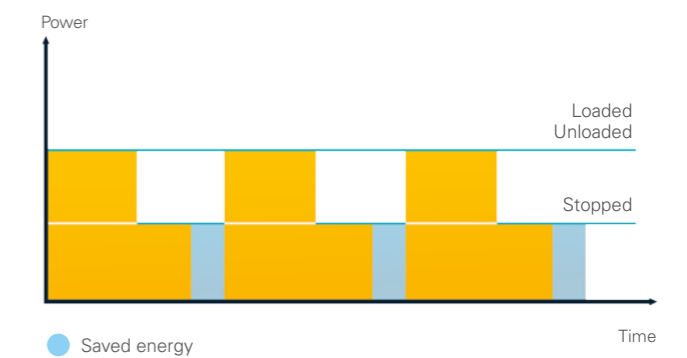

Integrated Dryer Saver Cycle

Saver Cycle technology reduces the energy consumption of the integrated refrigerant dryers with the fan in light load applications. Using an ambient sensor to monitor the required dew point

suppression, the Elektronikon® starts and stops the dryer and the fan, minimizing energy use and protecting the air system from corrosion.

EXCELLENCE IN INTEGRATED AIR QUALITY

Untreated compressed air contains moisture, aerosols and dirt particles that can damage your air system and contaminate your end product, resulting in risk of corrosion and compressed air system leaks. Maintenance costs can far exceed air treatment costs. Our compressors provide the clean, dry air that improves your system's reliability, avoids costly downtime and production delays, and safeguards the quality of your products.

Save money and the environment

Avoid risk of corrosion and system leaks, and ensure the effective safe disposal of untreated condensate – all within ISO 14001 standards.

ZERO OZONE DEPLETION



On average 50% energy savings with R410A integrated dryers

- Use of energy-efficient refrigerant R410A reduces operating costs.
- R410A refrigerant reduces global warming potential by an average of 50%.
- Environmentally-friendly characteristics; zero ozone depletion.
- Unique Saver Cycle Control, with ambient temperature sensor and based on dryer load and relative humidity of compressed air, saves energy at partial load.
- Heat exchanger cross-flow technology with low pressure drop.
- Zero waste of compressed air thanks to no-loss condensate drain.
- Pressure dew point of 3°C (100% relative humidity at 20°C).

Integrated purity

The optional UD+ filter and integrated refrigerant air dryer (IFD) efficiently remove moisture, aerosols and dirt particles to protect your investment.

This air quality prolongs the life of downstream equipment, increasing efficiency and ensuring quality of your final product.

	ISO quality class*	Dirt particle size	Water pressure dew point**	Oil concentration
PACK COMPRESSOR	3..4	3 microns	-	3 ppm
INTEGRATED REFRIGERANT DRYER	3.4.4	3 microns	+3°C, 37°F	3 ppm
UD+*	1.4.2	0.01 microns	+3°C, 37°F	0.01 ppm

* The table values reflect the maximum limits according to the temperature ISO gravity class.
 ** Water pressure dew point based on 100% RH at 20°C/68°F.



WORKPLACE: COMPRESSED AIR AT THE POINT OF USE

With the industry-leading low noise operation and integration of air and condensate treatment equipment, the GA+ offers complete versatility for your production. The compressor's integrated design allows it to be placed on the production floor, creating substantial energy savings for your business.



Low installation costs

- The GA+ can operate close to the point of use – eliminating the need for a dedicated compressor room.
- The GA+ is delivered ready for use – minimizing production downtime and reducing installation costs.
- Filtration equipment is integrated – reducing the need for costly external piping and minimizing pressure drops.
- Low noise enables the above to be a reality.

Reduced energy and maintenance costs

- With less external piping, the GA+ minimizes pressure drop across the system which can reduce energy costs.
- The filtration system produces clean air to prevent network corrosion – minimizing energy, repair and maintenance costs.
- The GA+ operates at the lowest possible system pressure to reduce energy costs thanks to the Elektronikon® advanced monitoring system.

Integrated condensate management

- OSCI is an efficient integrated solution that removes oil from condensate.
- Oil carryover contained in condensate can harm the environment.
- Treated condensate protects water, wildlife and ecosystems.
- The delivered water is harmless and can be disposed in a sewage system, reducing disposal costs.

OPTIMIZE YOUR SYSTEM

Some applications may need or may benefit from additional options and more refined control/air treatment systems. To meet these needs, Atlas Copco has developed options and easily integrated compatible equipment.

		GA 30*-90	GA 37-90 VSD
Air treatment	Integrated filter kit class 1*	✓	✓
	Integrated filter kit class 2*	✓	✓
	Dryer bypass*	✓	✓
Condensate	OSCi	✓	✓
Protection	Oil retaining frame	✓	✓
	Motor space heater	-	✓
	Motor space heater + thermistors	✓	-
	Water shut-off valve**	✓	✓
	Phase sequence relay (GA 55-90)	✓	-
	Tropical thermostat	✓	-
	Freeze protection	✓	✓
	NEMA 4 cubicle	✓	-
	NEMA 4X cubicle	✓	-
	Pre-filter	✓	✓
	Advanced monitoring	✓	✓
	ANSI flange outlet	✓	✓
	DIN flange outlet	✓	✓
	Public works	Rain protection	✓
Main power isolator switch		✓	✓
Lifting device		✓	✓
Oversized motor (except GA 45* & GA 90)		✓	-
Communication	ES 100 relays***	✓	✓
	AIReconnect	✓	✓
	Elektronik® Graphic upgrade (only for GA 37 to GA 75)	✓	-
	ES4/ES6i (for Elektronik® Graphic)	✓	✓
Oils	Digital I/O expansion module	✓	✓
	Food grade oil	✓	✓
General options	Roto – Xtend duty oil (8000 hours)	✓	✓
	Witness performance test	✓	✓
	Energy recovery	✓	✓
	Power duct fan	✓	✓
	Modulating control	✓	-
	High-ambient temperature version (HAV 55°C, 131°F)****	✓	✓
	IT/TT ancillaries	-	✓

*FF units only.
 ** Water-cooled units.
 *** Includes potential-free contacts: motor running, compressor load/unload.
 **** FF units max 50°C, 122°F.
 -: Not available

Integrated Energy Recovery

As much as 90% of the electrical energy used by a compressed air solution is converted into heat. Using Atlas Copco's integrated energy recovery systems, it is feasible to recover up to 75% of that power input as hot air or hot water without any influence

on the compressor's performance. Through efficient usage of the recovered energy, you bring about important energy cost savings and obtain a high return on investment.



Energy Recovery applications

- Auxiliary or main heating of warehouses, workshops etc.
- Industrial process heating.
- Water heating for laundries, industrial cleaning and sanitary facilities.
- Canteens and large kitchens.
- Food industry.
- Chemical and pharmaceutical industries.
- Drying processes.

FLOW CHARTS

VARIABLE SPEED DRIVE: GA VSD

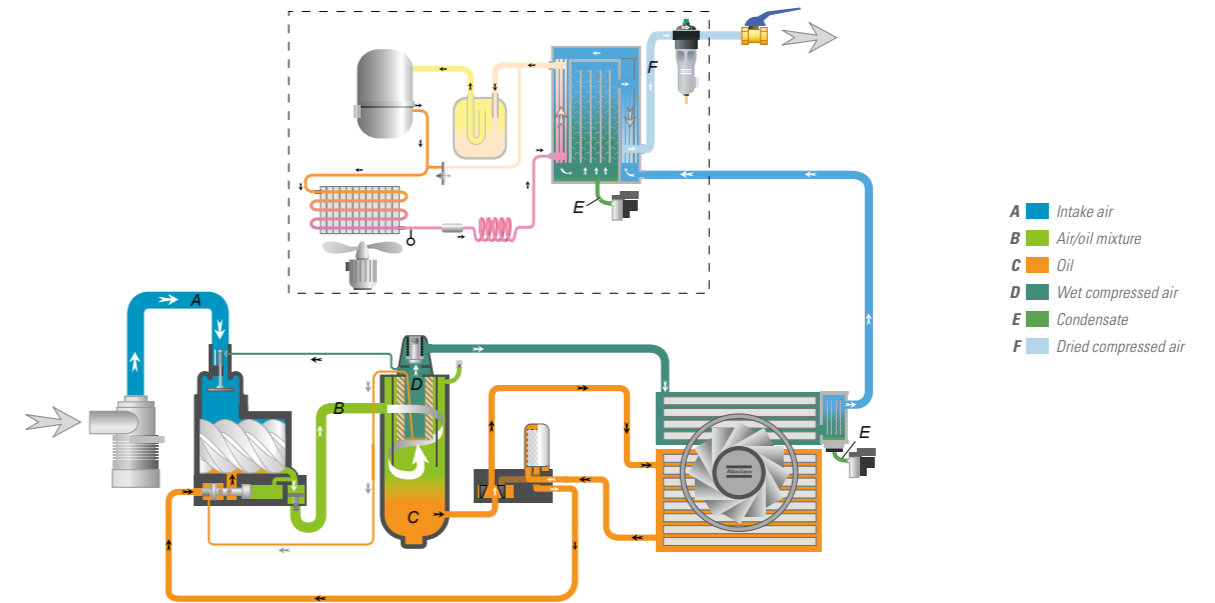

FIXED SPEED: GA+ & GA

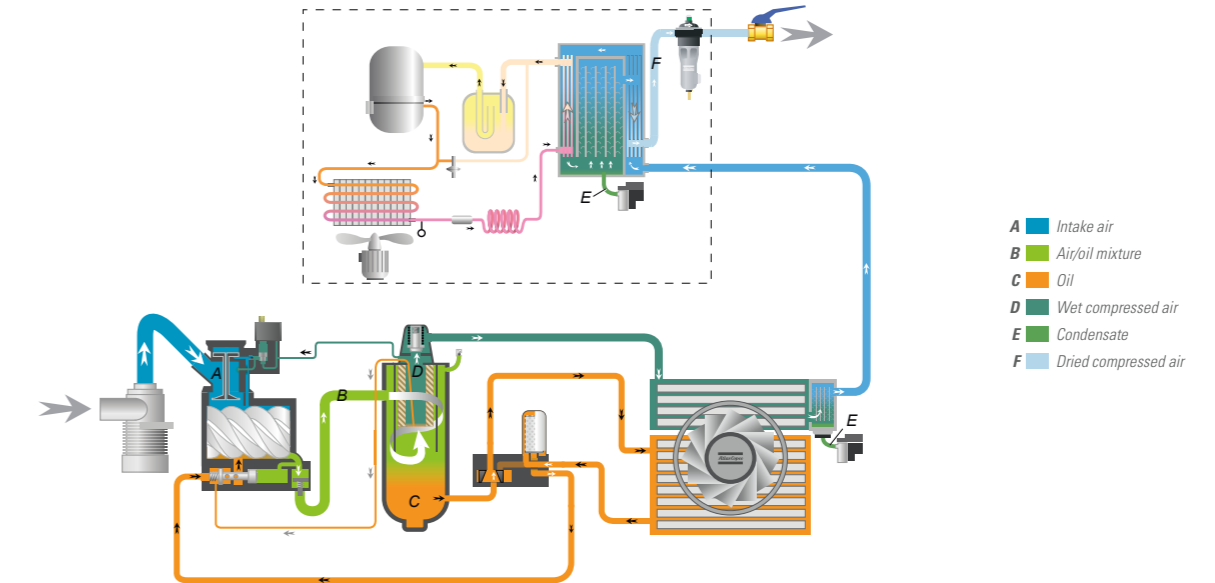

GA 37, 45 VSD
GA 30*, 37*, 45*
GA 37, 45

Width 1766 mm, 69.5"
 Depth 970 mm, 38.2"
 Height 1800 mm, 70.9"

GA 55, 75, 90 VSD
GA 55*, 75*
GA 55, 75, 90

Width 2248 mm, 88.5"
 Depth 1080 mm, 42.5"
 Height 1955 mm, 76.9"

TECHNICAL SPECIFICATIONS GA 30⁺-90 (50 HZ VERSIONS)

COMPRESSOR TYPE	Pressure variant	Max. working pressure WorkPlace		Capacity FAD*			Installed motor power		Noise level**	Weight WorkPlace		Weight WorkPlace Full Feature	
		bar(e)	psig	l/s	m ³ /min	cfm	kW	hp		kg	lbs	kg	lbs
GA 30 ⁺	7.5	7.5	109	99	5.9	209	30	40	65	817	1801	898	1980
	8.5	8.5	123	90	5.4	191	30	40	65	817	1801	898	1980
	10	10	145	82	4.9	175	30	40	65	817	1801	898	1980
GA 37	13	13	189	71	4.3	151	30	40	65	817	1801	898	1980
	7.5	7.5	109	115	6.9	243	37	50	69	905	1994	820	1807
	8.5	8.5	123	106	6.4	225	37	50	69	905	1995	820	1808
GA 37 ⁺	10	10	145	100	6.0	213	37	50	69	905	1995	820	1808
	13	13	189	81	4.9	172	37	50	69	905	1995	820	1808
	7.5	7.5	109	122	7.3	258	37	50	65	902	1989	987	2176
GA 45	8.5	8.5	123	118	7.1	250	37	50	65	902	1989	987	2176
	10	10	145	102	6.1	216	37	50	65	902	1989	987	2176
	13	13	189	85	5.1	180	37	50	65	902	1989	987	2176
GA 45 ⁺	7.5	7.5	109	137	8.2	291	45	60	72	894	1971	979	2158
	8.5	8.5	123	127	7.6	268	45	60	72	894	1971	979	2158
	10	10	145	117	7.0	248	45	60	72	894	1971	979	2158
GA 55	13	13	189	102	6.1	217	45	60	72	894	1971	979	2158
	7.5	7.5	109	149	8.9	315	45	60	66	970	2138	1060	2337
	8.5	8.5	123	139	8.3	295	45	60	66	970	2138	1060	2337
GA 55 ⁺	10	10	145	128	7.7	270	45	60	66	970	2138	1060	2337
	13	13	189	106	6.4	225	45	60	66	970	2138	1060	2337
	7.5	7.5	109	169	10.2	359	55	75	69	1229	2709	1329	2930
GA 75	8.5	8.5	123	159	9.5	336	55	75	69	1229	2709	1329	2930
	10	10	145	148	8.9	313	55	75	69	1229	2709	1329	2930
	13	13	189	126	7.6	267	55	75	69	1229	2709	1329	2930
GA 75 ⁺	7.5	7.5	109	184	11.1	390	55	75	66	1358	2994	1458	3214
	8.5	8.5	123	174	10.4	369	55	75	66	1358	2994	1458	3214
	10	10	145	156	9.5	331	55	75	66	1358	2994	1458	3214
GA 90	13	13	189	126	7.6	267	55	75	69	1229	2709	1329	2930
	7.5	7.5	109	226	13.5	478	75	100	73	1259	2776	1379	3040
	8.5	8.5	123	209	12.6	444	75	100	73	1259	2776	1379	3040
GA 90 ⁺	10	10	145	189	11.4	401	75	100	73	1259	2776	1379	3040
	13	13	189	162	9.7	344	75	100	73	1259	2776	1379	3040
	7.5	7.5	109	248	14.9	526	75	100	68	1413	3115	1533	3380
GA 90 ⁺	8.5	8.5	123	235	14.1	497	75	100	68	1413	3115	1533	3380
	10	10	145	210	12.6	445	75	100	68	1413	3115	1533	3380
	13	13	189	177	10.6	375	75	100	68	1413	3115	1533	3380
GA 90 ⁺	7.5	7.5	109	281	16.9	596	90	125	73	1425	3142	1545	3406
	8.5	8.5	123	275	16.5	582	90	125	73	1425	3142	1545	3406
	10	10	145	250	15.0	529	90	125	73	1425	3142	1545	3406
GA 90 ⁺	13	13	189	216	13.0	458	90	125	73	1425	3142	1545	3406

* Unit performance measured according to ISO 1217, Annex C, Edition 4:2009.

Reference conditions:

- Absolute inlet pressure 1 bar (14.5 psi)
- Intake air temperature 20°C, 68°F

FAD is measured at the following working pressures:

- 7.5 bar versions at 7 bar
- 8.5 bar versions at 8 bar
- 10 bar versions at 9.5 bar
- 13 bar versions at 12.5 bar

** A-weighted emission sound pressure level at the work station, Lp WSA (re 20 µPa) dB (with uncertainty 3 dB).

Values determined according to noise level test code ISO 2151 and noise measurement standard ISO 9614.

Pressure dew point of integrated refrigerant dryer at reference conditions: 2°C to 3°C, 36°F to 37°F



TECHNICAL SPECIFICATIONS GA 30⁺-90 (60 HZ VERSIONS)

COMPRESSOR TYPE	Pressure variant	Max. working pressure WorkPlace		Capacity FAD*			Installed motor power		Noise level**	Weight WorkPlace		Weight WorkPlace Full Feature	
		bar(e)	psig	l/s	m ³ /min	cfm	kW	hp		kg	lbs	kg	lbs
GA 30 ⁺	100	7.4	107	100	6.0	212	30	40	65	817	1801	898	1980
	125	9.1	132	91	5.4	192	30	40	65	817	1801	898	1980
	150	10.8	157	82	4.9	174	30	40	65	817	1801	898	1980
GA 37	175	12.5	181	75	4.5	158	30	40	65	817	1801	898	1980
	100	7.4	107	116	7.0	246	37	50	69	905	1995	820	1808
	125	9.1	132	108	6.5	229	37	50	69	905	1995	820	1808
GA 37 ⁺	150	10.8	157	96	5.8	204	37	50	69	905	1995	820	1808
	175	12.5	181	87	5.2	185	37	50	69	905	1995	820	1808
	100	7.4	107	120	7.2	255	37	50	65	905	1995	987	2176
GA 45	125	9.1	132	111	6.6	234	37	50	65	905	1995	987	2176
	150	10.8	157	100	6.0	212	37	50	65	905	1995	987	2176
	175	12.5	181	91	5.4	192	37	50	65	905	1995	987	2176
GA 45 ⁺	100	7.4	107	139	8.3	294	45	60	72	894	1971	979	2158
	125	9.1	132	128	7.7	271	45	60	72	894	1971	979	2158
	150	10.8	157	118	7.1	250	45	60	72	894	1971	979	2158
GA 55	175	12.5	181	105	6.3	222	45	60	72	894	1971	979	2158
	100	7.4	107	146	8.8	310	45	60	66	970	2138	1060	2337
	125	9.1	132	134	8.0	284	45	60	66	970	2138	1060	2337
GA 55 ⁺	150	10.8	157	126	7.5	266	45	60	66	970	2138	1060	2337
	175	12.5	181	111	6.7	236	45	60	66	970	2138	1060	2337
	100	7.4	107	174	10.5	369	55	75	69	1229	2709	1329	2930
GA 75	125	9.1	132	154	9.3	327	55	75	69	1229	2709	1329	2930
	150	10.8	157	142	8.5	300	55	75	69	1229	2709	1329	2930
	175	12.5	181	128	7.7	272	55	75	69	1229	2709	1329	2930
GA 75 ⁺	100	7.4	107	184	11.0	390	55	75	67	1358	2994	1458	3214
	125	9.1	132	166	10.0	352	55	75	67	1358	2994	1458	3214
	150	10.8	157	141	8.5	299	55	75	67	1358	2994	1458	3214
GA 90	175	12.5	181	129	7.3	259	55	75	69	1229	2709	1329	2930
	100	7.4	107	229	13.7	485	75	100	73	1259	2776	1359	2996
	125	9.1	132	200	12.0	424	75	100	73	1259	2776	1359	2996
GA 90 ⁺	150	10.8	157	189	11.4	401	75	100	73	1259	2776	1359	2996
	175	12.5	181	169	10.1	358	75	100	73	1259	2776	1359	2996
	100	7.4	107	248	14.9	525	75	100	69	1413	3115	1533	3380
GA 90 ⁺	125	9.1	132	227	13.6	481	75	100	69	1413	3115	1533	3380
	150	10.8	157	204	12.3	433	75	100	69	1413	3115	1533	3380
	175	12.5	181	182	10.9	385	75	100	69	1413	3115	1533	3380
GA 90 ⁺	100	7.4	107	289	17.4	613	90	125	74	1425	3142	1545	3406
	125	9.1	132	267	16.0	565	90	125	74	1425	3142	1545	3406
	150	10.8	157	250	15.0	530	90	125	74	1425	3142	1545	3406
GA 90 ⁺	175	12.5	181	228	13.7	484	90	125	74	1425	3142	1545	3406

Please refer to the footnotes, reference conditions and FAD details of the 50 Hz versions.

TECHNICAL SPECIFICATIONS GA 37-90 VSD (50/60 HZ VERSIONS)

COMPRESSOR TYPE	Working pressure		Capacity FAD*						Installed motor power		Noise level**	Weight WorkPlace		Weight WorkPlace Full Feature	
			l/s		m ³ /min		cfm								
	bar(e)	psig	min	max	min	max	min	max	kW	hp	dB(A)	kg	lbs	kg	lbs
GA 37 VSD	4	58	26.0	124	1.6	7.4	55	263	37	50	66/67	1042	2297	1127	2485
	7	102	26.0	123	1.6	7.4	55	260	37	50	66/67	1042	2297	1127	2485</

COMMITTED TO SUSTAINABLE PRODUCTIVITY

We stand by our responsibilities towards our customers, towards the environment and the people around us. We make performance stand the test of time. This is what we call – Sustainable Productivity.



www.atlascopco.com

